

Warning

- Only qualified service personnel should install and service this product to avoid injury.
- Observe all ESD procedures during installation to avoid damaging the equipment.

1 Preparing tools

Unpack the equipment and make sure the following tools are available and delivered contents are correct.

- 1-1. User-provided tools
 - Anti-static wrist wrap
- 1-2. Packing List

Item	Description	Quantity
01	Nuvo-9000VTC series system	1
02	CPU bracket	1
03	Nuvo-9100VTC damping bracket Nuvo-9200VTC damping bracket kit (L+R)	1
04	Foot pad	4
05	3-pin pluggable terminal block	2
06	2.5" HDD/SSD thermal pad (if HDD not installed)	1
07	Rubber spacer (barebone system only)	4
08	Screw pack	1
09	12x grommets (Nuvo-9100VTC) 4x grommets + 4x sleeves (Nuvo-9200VTC)	

2 Overview - Front Panel

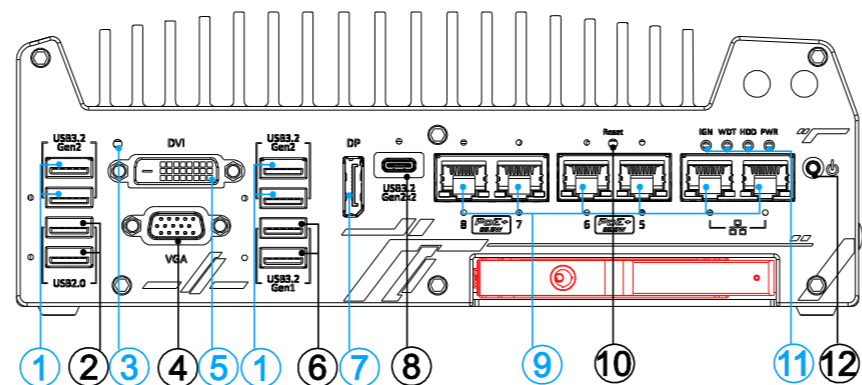

Nuvo-9100VTC Series

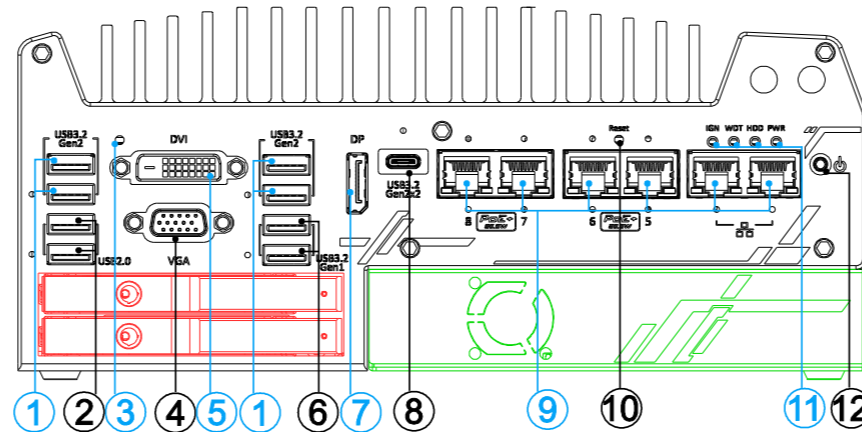

Nuvo-9200VTC Series

No.	Item	Description
1	USB3.2 Gen2x1 port	USB3.2 Gen 2 port (SuperSpeed+) offers up to 10Gbps, twice the bandwidth over existing SuperSpeed USB3.2 Gen. 1 connection. It is also backwards compatible with USB3.0 and USB2.0
2	USB2.0 port	The USB 2.0 ports offer up to 480Mbit/s bandwidth and are backward compatible with USB 1.1/ 1.0
3	CMOS reset button	Use this button to manually to reset the CMOS to load default BIOS
4	VGA port	VGA output supports resolution up to 1920 x 1200@60Hz
5	DVI port	DVI-D output supports resolution up to 1920 x 1200@60Hz and is compatible with other digital connections via an adapter
6	USB3.1 Gen1x1 port	USB3.1 Gen 1 offers up to 5Gbps of data-throughput performance
7	DisplayPort	Support display resolutions up to 4096 x 2304 @ 60Hz. Compatible with HDMI/ DVI via respective adapter/ cable (resolution may vary)
8	USB3.2 Gen2x2 Type-C port	The USB 3.2 Gen2x2 type-C port offers up to 20Gbps of bandwidth connectivity for fast data exchange with external devices
9	Ethernet & PoE+ port	1x 2.5GbE by I225 and 1x GbE by I219 with screw-lock Additional 4x 2.5GbE by I225 (Nuvo-9108/ 9208VTC) with screw-lock
10	Reset button	Use this button to manually reset the system
11	Status LED indicators	From left to right, the LEDs are IGN (ignition control), WDT (watchdog timer), HDD (hard disk drive) and PWR (system power)
12	Power button	Use this button to turn on or shutdown the system
Area in Green	Cassette module	The cassette module offers a separate compartment to manage thermal conditions and reduce installation complications of an add-on card
Area in Red	2.5" HDD/SSD Tray	The HDD expansion tray offer hot-swap ability (1x tray for Nuvo-9100VTC systems and 2x trays for Nuvo-9200VTC systems)

3 USB3.2 Gen2x1 Port

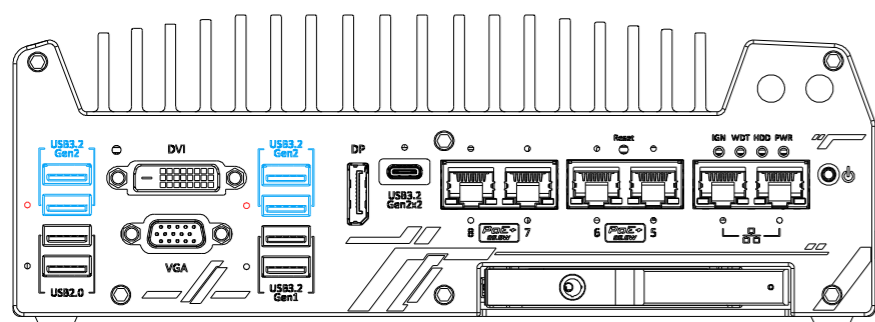

The system's USB 3.2 Gen2x1 ports (10Gbps) are implemented via native xHCI (eXtensible Host Controller Interface) controller and are backward compatible with USB3.2 Gen.1 USB 2.0, USB 1.1 and USB 1.0 devices. UEFI USB is also supported so you can use USB keyboard/ mouse in UEFI shell environment. Indicated in red are screw-lock holes for the corresponding USB port. xHCI driver is supported natively in Windows 10, therefore you do not need to install the xHCI driver prior to utilizing USB functions.

4 USB2.0 Port

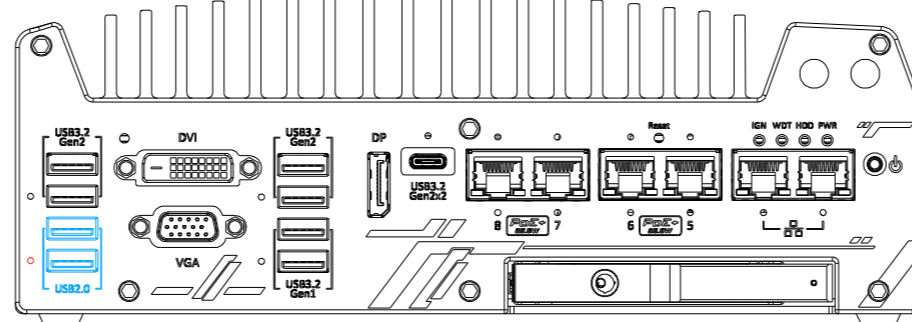

The USB2.0 ports are implemented via native xHCI (eXtensible Host Controller Interface) and are backward compatible with USB 1.1 and USB 1.0 devices. UEFI USB support is also provided so you can use USB keyboard/ mouse in UEFI shell environment. Indicated in red is a screw-lock hole for the corresponding USB port. xHCI driver is supported natively in Windows 10, therefore you do not need to install xHCI driver to utilize USB functions.

5 CMOS Reset Button

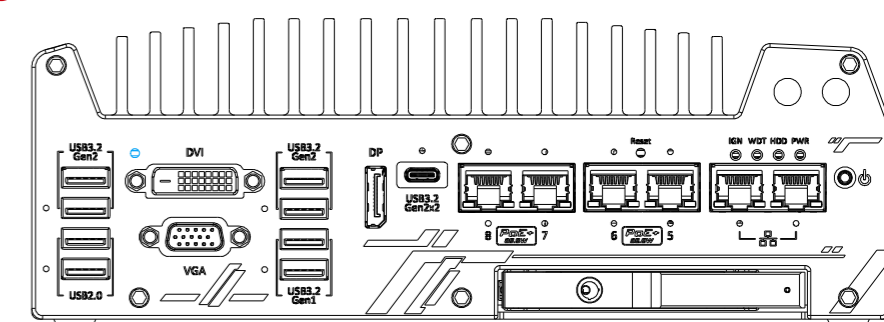

The CMOS Reset button is used to manually reset the motherboard BIOS in case of system halt or malfunction. To avoid unexpected operation, it is purposely placed behind the panel. To reset, disconnect the DC power input, and use the tip of a pen to press and hold for at least 5 seconds to reset the BIOS.

Note

You MUST unplug the DC connection to the system before resetting the CMOS.

Warning

Clearing the CMOS will reset all BIOS settings to default and may result in down time!

6 VGA Port

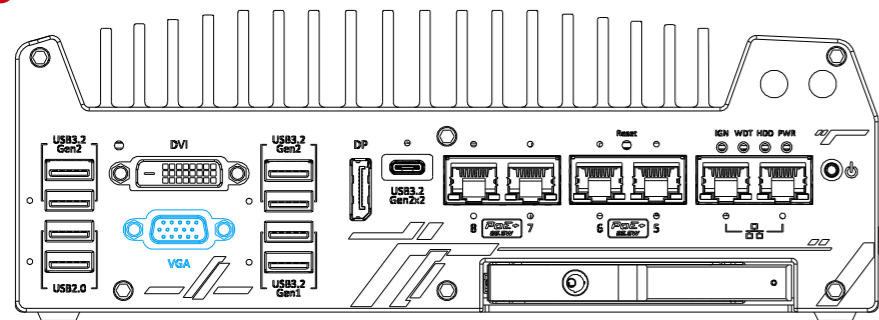

VGA connector is the most common video display connection. The VGA output supports up to 1920x1200@60Hz resolution. The system supports triple independent display outputs by connecting display devices to VGA, DVI and DisplayPort connection. To support multiple display outputs and achieve best VGA output resolution in Windows, you need to install corresponding graphics drivers.

Note

Please make sure your VGA cable includes SDA and SCL (DDC clock and data) signals for correct communication with monitor to get resolution/timing information. A cable without SDA/ SCL can cause blank screen on your VGA monitor due to incorrect resolution/timing output.

7 DVI Port

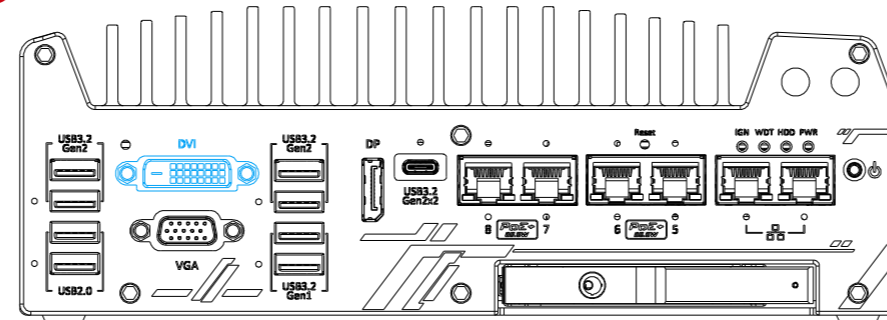

DVI-D transmits graphics data in digital format and therefore can deliver better image quality at high resolution. The DVI connector on the front panel can either output DVI signals or other digital signals (via an adapter/ cable) depending on the display device connected. It supports resolutions up to 1920x1200@60Hz. The system supports triple independent display outputs by connecting display devices to VGA, DVI and DisplayPort connection. To support multiple display outputs and achieve best DVI output resolution in Windows, you need to install corresponding graphics driver.

8 USB 3.2 Gen1x1 Port

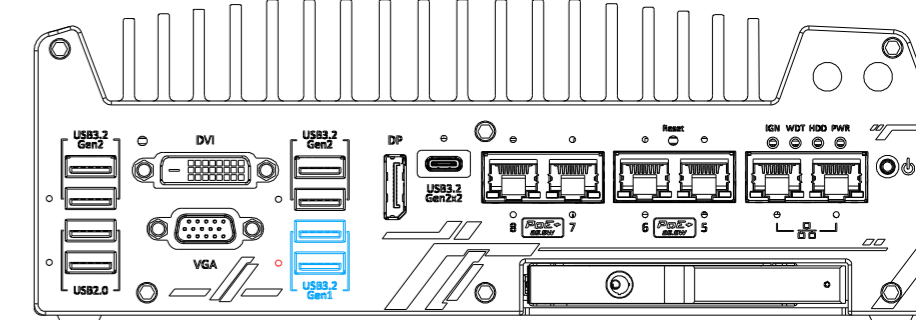

The system's USB 3.2 Gen1x1 ports (5Gbps) are implemented via native xHCI (eXtensible Host Controller Interface) controller and are backward compatible with USB 2.0, USB 1.1 and USB 1.0 devices. UEFI USB is also supported so you can use USB keyboard/mouse in UEFI shell environment. Indicated in red is a screw-lock hole for the corresponding USB port. xHCI driver is supported natively in Windows 10, therefore you do not need to install the xHCI driver prior to utilizing USB functions.

9 DisplayPort

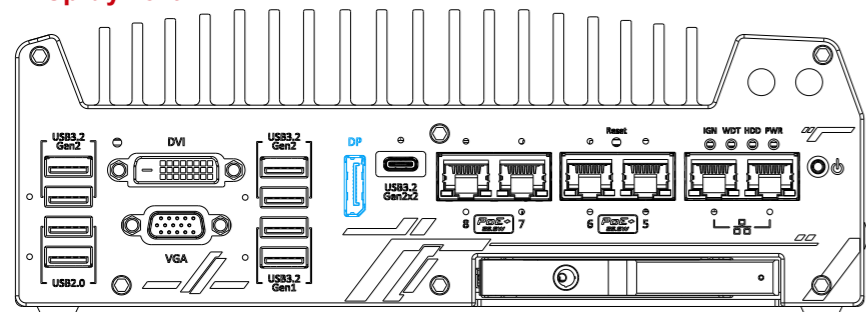

The system has a DisplayPort (DP) output which is a digital display interface that mainly connect video source and carry audio to a display device. When connected to a DP, it can deliver up to 8K UHD (7680 x 4320 @ 60Hz) in resolution. The system is designed to support passive DP adapter/ cable. You can connect to other display devices using DP-to-HDMI cable or DP-to-DVI cable.



The system supports triple independent display outputs by connecting display devices to VGA, DVI and DisplayPort connection. To support multiple display outputs and achieve best DisplayPort output resolution in Windows, you need to install corresponding graphics drivers.

10 USB 3.2 Gen2x2 Type-C Port

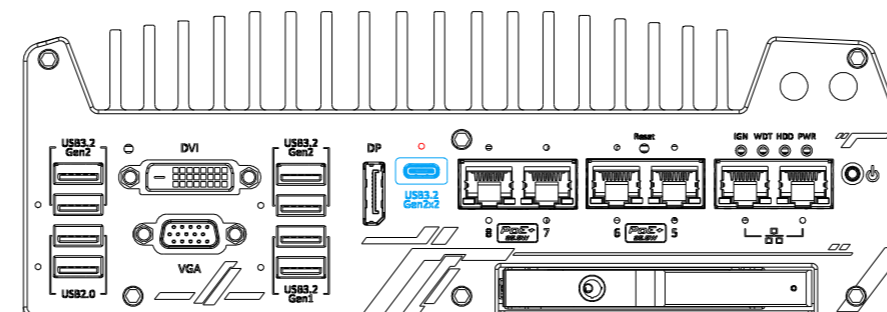

The system's USB 3.2 Gen2x2 type-C port offers up to 20Gbps of data transfer bandwidth, and is implemented via the native xHCI (eXtensible Host Controller Interface) controller. The port is backward compatible with USB3.2 Gen.1 USB 2.0, USB 1.1 and USB 1.0 devices via a USB hub (not included) to connect to external devices. xHCI driver is supported natively in Windows 10, therefore you do not need to install the xHCI driver prior to utilizing USB functions.

11 2.5G Ethernet and PoE+ Ports

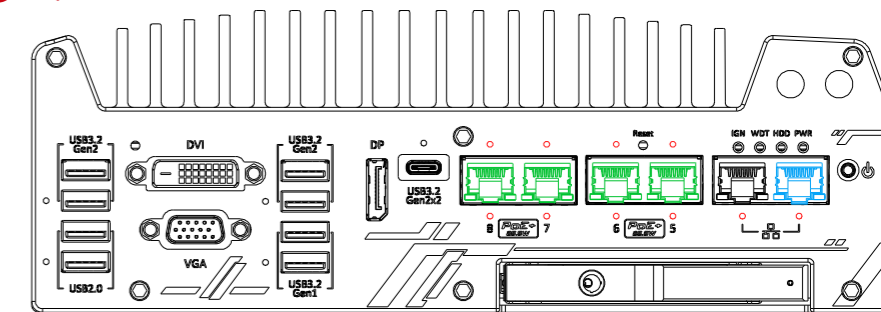

The ports marked in green/ black are Power over Ethernet (PoE) ports implemented with Intel I225-IT 2.5G Ethernet controller, and marked in blue is implemented using Intel® I219-LM controller that supports Wake-on-LAN and is also compatible with Intel® AMT (Active Management Technology) to support advanced features such as remote SOL desktop and remote on/ off control. The PoE+ ports feature panel screw fix holes (indicated in red) for a firm and secure connection. The ports supply electrical power and data on a standard CAT-5/CAT-6 Ethernet cable. Acting as a PoE PSE (Power Sourcing Equipment), compliant with IEEE 802.3at, each PoE port delivers up to 25W to a Powered Device (PD), and the system has a total 100W power PoE budget.

Active/Link LED (Right)

LED Color	Status	Description
Orange	Off	Ethernet port is disconnected
	On	Ethernet port is connected and no data transmission
	Flashing	Ethernet port is connected and data is transmitting/receiving

Speed LED (Left)

LED Color	Status	Description
Green or Orange	Off	10 Mbps
	Green	100 Mbps
	Orange	1000/ 2500 Mbps

12 Reset Button

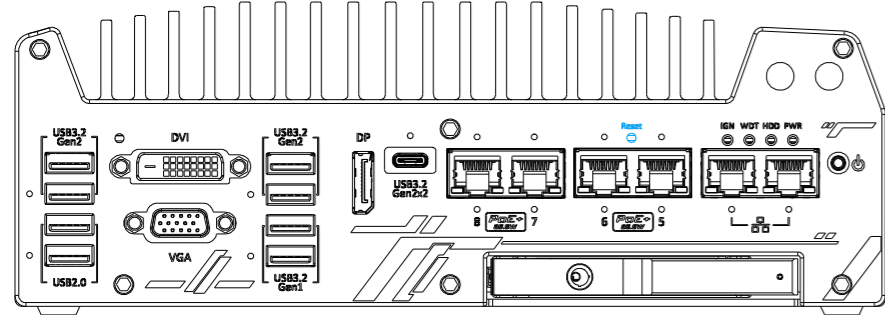

The reset button is used to manually reset the system in case of system halt or malfunction. To avoid unexpected reset, the button is purposely placed behind the panel. To reset, please use a pin-like object (eg. tip of a pen) to access the reset button.

13 Status LED Indicator

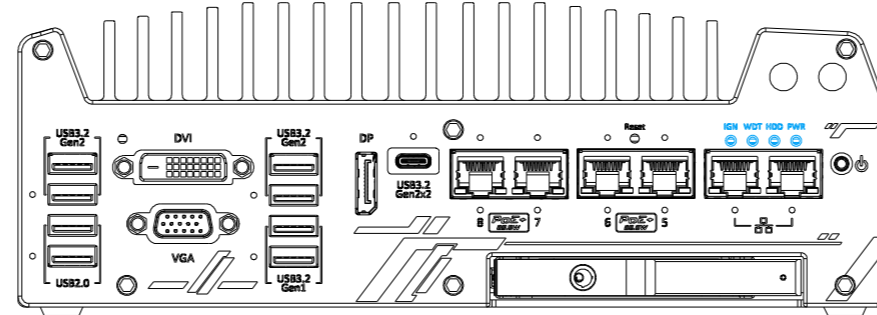

There are four LED indicators on the I/O panel: IGN, WDT, HDD and PWR. The descriptions of these four LED are listed in the following table.

Indicator	Color	Description
IGN	Yellow	Ignition signal indicator, lid when IGN is high (12V/ 24V).
WDT	Yellow	Watchdog timer LED, flashing when WDT is active.
HDD	Red	Hard drive indicator, flashing when hard disk drive is active.
PWR	Green	Power indicator, lid when system is on.

14 Power Button

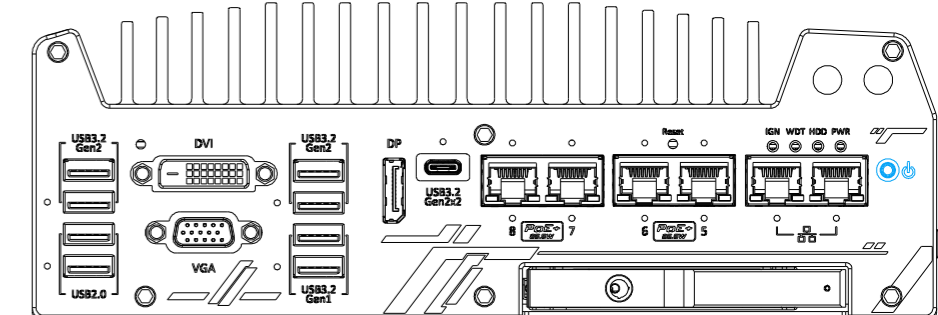

The power button is a non-latched switch for ATX mode on/off operation. To turn on the system, press the power button and the PWR LED should light-up green. To turn off the system, issuing a shutdown command in OS is preferred, or you can simply press the power button. To force shutdown when the system freezes, press and hold the power button for 5 seconds. Please note that there is a 5-second interval between on/off operations (i.e. once the system is turned off, there is a 5-second wait before you can power-on the system).

15 2.5" HDD/SSD Hot Swappable Tray

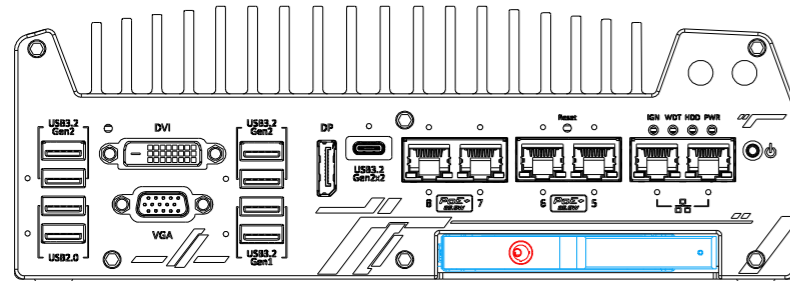

Nuvo-9100VTC

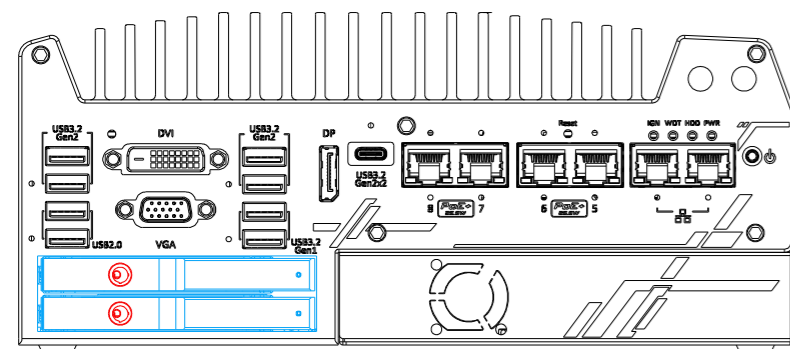

Nuvo-9200VTC

The Nuvo-9100VTC systems support an external 2.5" HDD/ SSD via a hot-swappable slot while Nuvo-9200VTC systems support two external 2.5" HDD/ SSD via hot-swappable slots. Designed for easy access, the HDD/ SSD slot is secured by a lock (indicated in red).

Note

The tray supports up to 9.5mm thickness HDD/ SSD.

16 Cassette Module

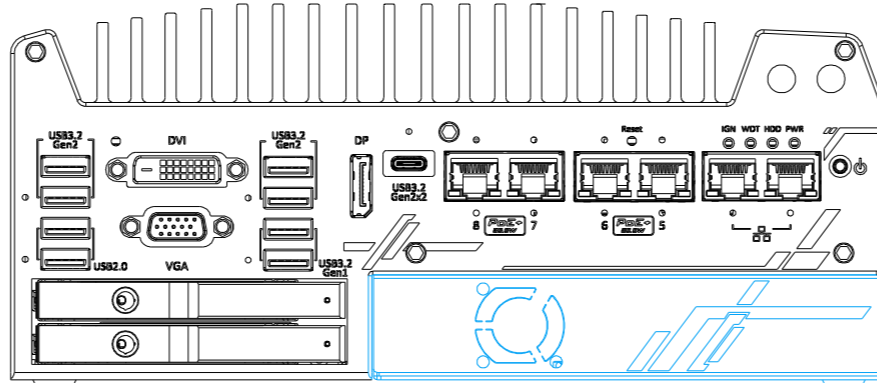

The Nuvo-9200VTC systems features a Neusys' patented expansion Cassette (R.O.C. Patent No. M456527) that provides a separated compartment to accommodate an add-on card. It effectively manages thermal conditions of both the system and the add-on card. The modular concept brought by Cassette module also reduces the complexity of installing and replacing an add-on card in the fanless controller.

17 Rear Panel IO

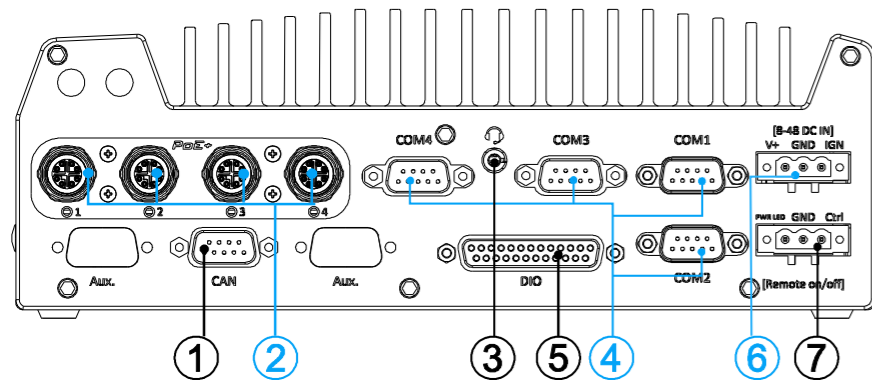

Nuvo-9100VTC

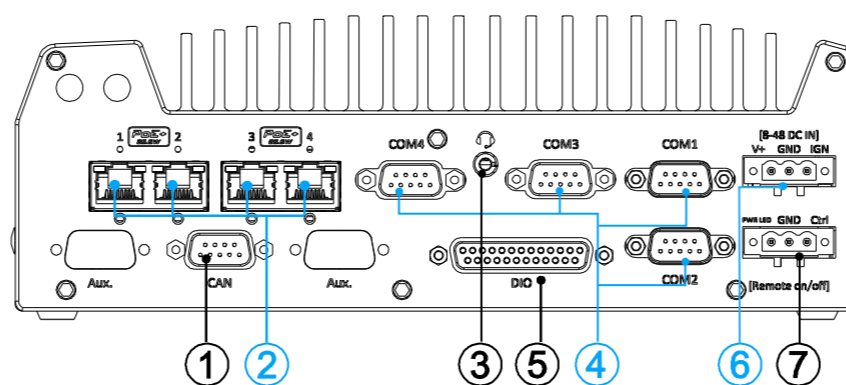

Nuvo-9104/ 9108VTC

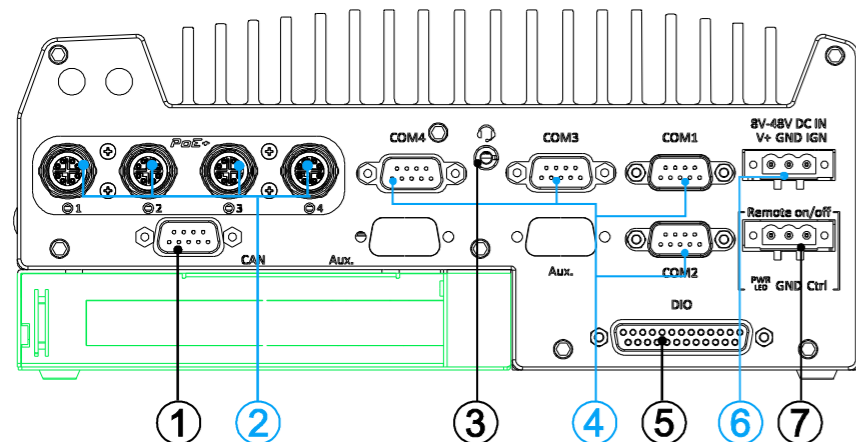

Nuvo-9200VTC

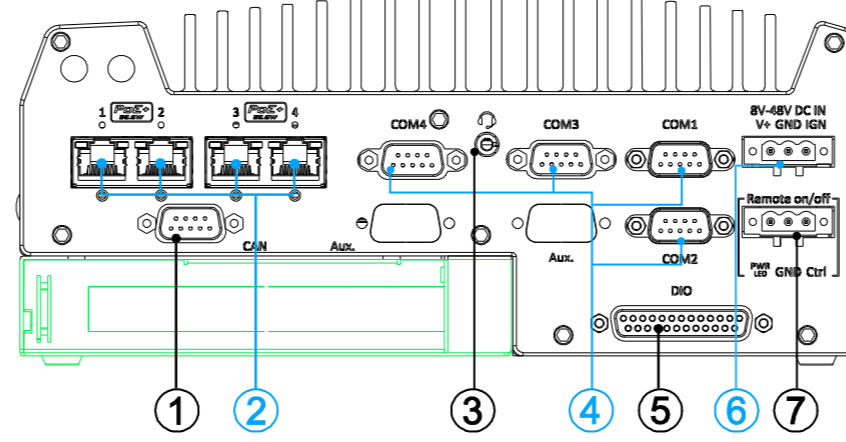

Nuvo-9204/ 9208VTC

No.	Item	Description
1	CAN bus	Allows controller to communicate with other in-vehicle CAN device(s).
2	PoE+ GbE port	M12 x-coded connector is applicable to Nuvo-9100/ 9200VTC systems. The rugged connection guarantees signal integrity while providing both data and electric power to devices. RJ45 Ethernet is applicable to Nuvo-9104/ 9204/ 9108/ 9208VTC systems. The Power over Ethernet (PoE) port can provide both data connection and electric power to devices.
3	Headphone/ microphone jack	The 4-pole 3.5mm jack accepts microphone voice input and headphone speaker sound output.
4	COM ports 1-4	The four COM ports offer communication with external devices.
5	Digital I/O	The DIO port provides 4x isolated digital input and 4x isolate output channels.
6	3-pin terminal block (DC/ ignition input)	Compatible with DC power input from 8V to 48V, the terminal block is also used for ignition signal input.
7	3-pin remote on/off control	Allows for external switch extension when the system is placed inside a cabinet.
Area in green	Cassette module	The cassette module offers a separate compartment to manage thermal conditions and reduce installation complications of an add-on card. Nuvo-9200VTC series features 1x PCIe x16 slot@Gen.3 (16-lanes) for add-on card expansion.

18 CAN bus Port

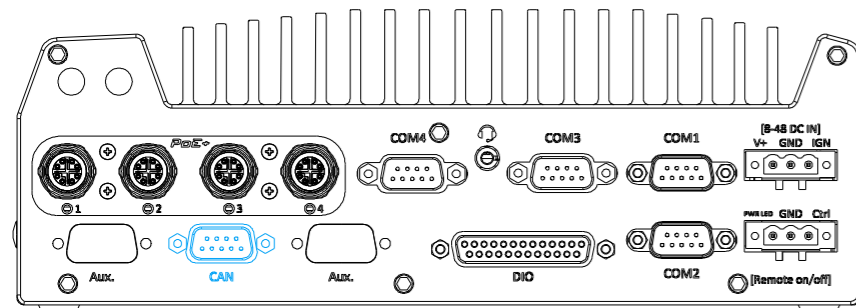

CAN bus is a robust industrial bus with a pair of differential signals and is commonly used in various industrial and in-vehicles applications. The system is equipped with a CAN bus DB9 port that is compatible with both industrial and in-vehicle applications. The CAN bus port supports CAN2.0A and CAN2.0B up to 1Mbps.

Pin Definition

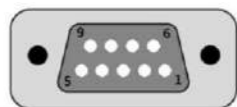

Pin No.	Definition	I/O	Description
1	GND	-	GND
2	Reserved	-	Reserved pin. Keep unconnected
3	CAN_H	I/O	CAN Bus High-level voltage
4	Reserved	-	Reserved pin. Keep unconnected
5	CAN_L	I/O	CAN Bus Low-level voltage
6	Reserved	-	Reserved pin. Keep unconnected
7	Reserved	-	Reserved pin. Keep unconnected
8	Reserved	-	Reserved pin. Keep unconnected
9	Reserved	-	Reserved pin. Keep unconnected

19 M12 Power over Ethernet Port (Nuvo-9100/ 9200VTC)

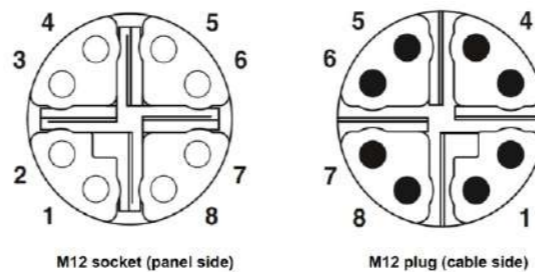
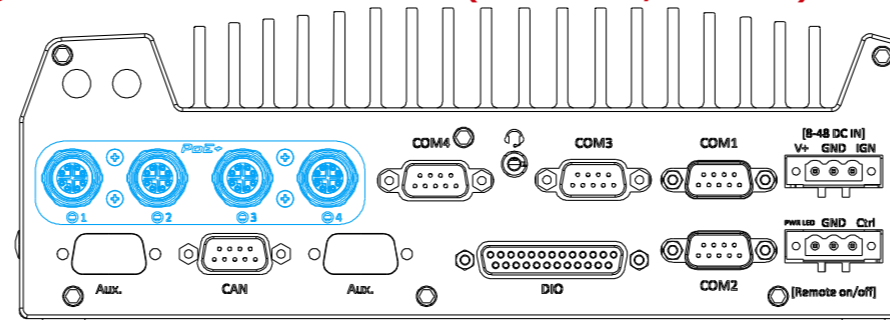

M12 Pin and Corresponding RJ45 Wire Connection

Wire color	Signal	M12 Pin	RJ45 Wire
Orange	D1+	1	1
Orange/White	D1-	2	2
Green	D2+	3	3
Blue	D3+	8	4
White	D3-	7	5
Green/White	D2-	4	6
Brown	D4+	5	7
Brown/White	D4-	6	8

PoE ports are provided via 8-pole, x-coded M12 connectors, offering extraordinary reliability for Ethernet connection. Power over Ethernet (PoE) supplies electrical power along with data on a standard Ethernet cable. As an IEEE 802.3at compliant PSE (Power Sourcing Equipment), each PoE port can deliver up to 25W of power to a Powered Device (PD), such as an IP camera. PoE is able to automatically detect the device connected and determine whether to dispatch power thus it is also compatible with traditional Ethernet devices.

RJ45 Power over Ethernet Port (Nuvo-9x04/ 9x08VTC)

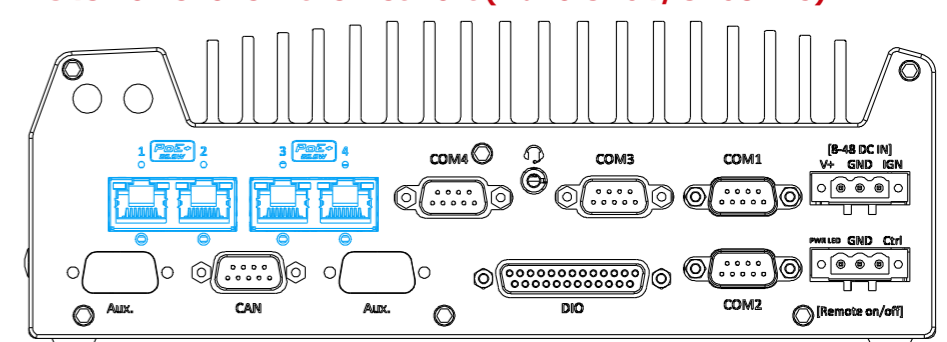

The ports supply electrical power along with data on a standard CAT-6 Ethernet cable. Acting as a Power Source Equipment (PSE), compliant with IEEE 802.3at standard, each port can deliver up to 25W of power to a Powered Device (PD), such as a PoE IP camera. PoE is able to automatically detect the device connected and determine whether to dispatch power thus it is also compatible with traditional Ethernet devices.

Active/Link LED

LED Color	Status	Description
Yellow	Off	Ethernet port is disconnected
	On	Ethernet port is connected and no data transmission
	Flashing	Ethernet port is connected and data is transmitting/receiving

Speed LED

LED Color	Status	Description
Green or Orange	Off	10 Mbps
	Green	100 Mbps
	Orange	1000 Mbps

20 3. 5mm Headphone/ Microphone Jack

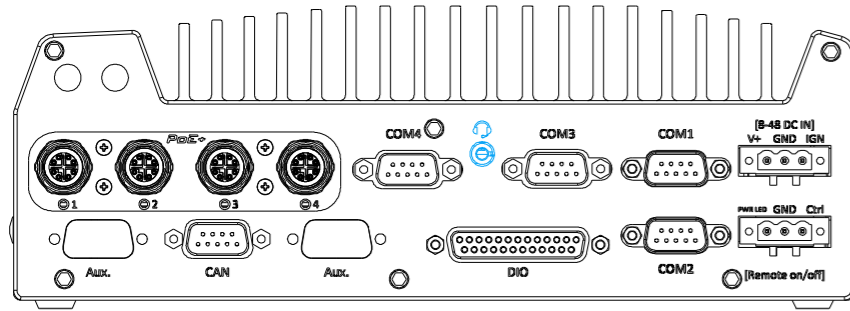

The system audio function uses high definition audio. There is a female 4-pole audio jack for headphone (speaker) output and microphone input. The HD audio codec is natively supported in Windows 10 and 11, and no additional drivers are required.

21 COM Ports

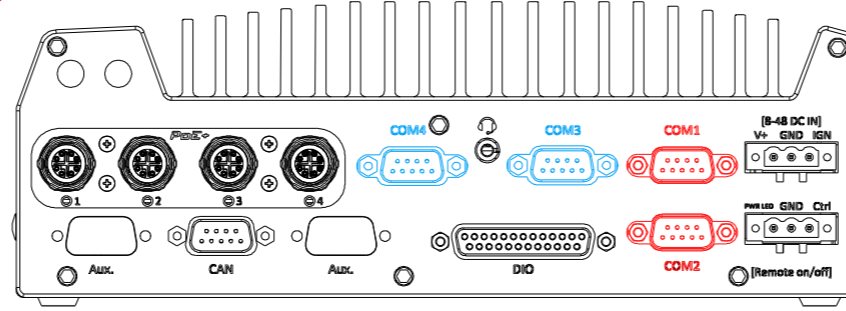

COM1 and COM2 (in red) are software-configurable RS-232/ 422/ 485 ports. COM3 and COM4 (in blue) are standard 9-wire RS-232 ports. The operation mode of COM1 and COM2 can be set in BIOS setup utility. The following table describes the pin definition of COM ports.

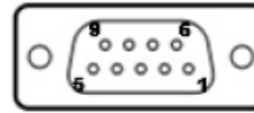

Pin#	COM1 & COM2			COM3 & COM4
	RS-232 Mode	RS-422 Mode	RS-485 Mode (Two-wire 485)	RS-232 Mode
1	DCD			DCD
2	RX	422 TXD+	485 TXD+/RXD+	RX
3	TX	422 RXD+		TX
4	DTR	422 RXD-		DTR
5	GND	GND	GND	GND
6	DSR			DSR
7	RTS			RTS
8	CTS	422 TXD-	485 TXD-/RXD-	CTS
9	RI			RI

22 Digital Input/ Output

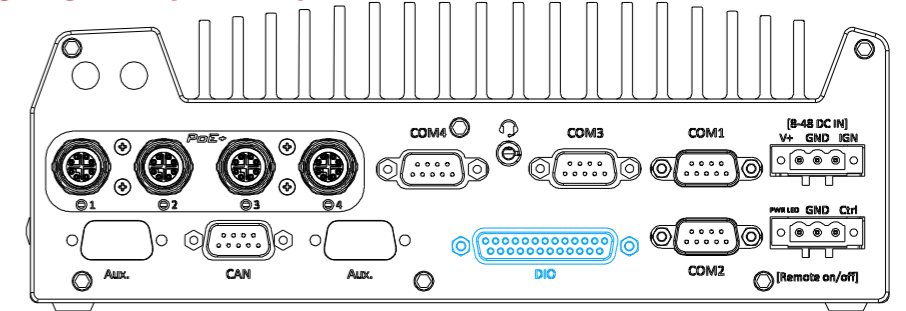

The system provides 4x isolated digital input channels and 4x isolated digital output channels. The DIO functions support polling mode I/O access and DI change-of-state interrupt.

Isolated Digital Input	
No. of Channel	4-CH Isolated Digital Input Channels
Logic Level	Logic High: 5 to 24V Logic Low: 0 to 1.5V
Isolated Voltage	2500 Vrms
Input Resistance	1kΩ
Operation Mode	Polling I/O, Change-of-State Interrupt
Isolated Digital Output	
No. of Channel	4-CH Isolated Digital Output Channels
Sink Current (per channel)	100 mA (sustained loading) 250 mA (peak loading)
Isolated Voltage	2500 Vrms
Operation Mode	Polling, Change-of-State Interrupt
Output Type	Power MOSFET + Analog Device iCoupler®
Operation Mode	Polling I/O and Change-of-State interrupt for DI

23 3-pin Terminal Block for DC and Ignition Input

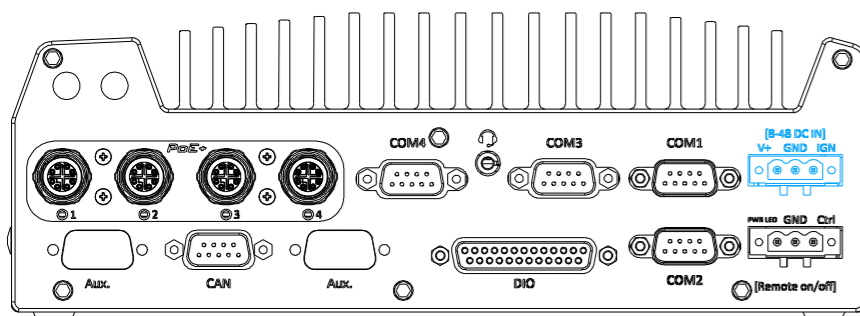

The system accepts a wide range of DC power input from 8 to 48V via a 3-pin pluggable terminal block, which is fit for field usage where DC power is usually provided. The screw clamping mechanism on the terminal block offers connection reliability when wiring DC power.

In addition to DC power input, this terminal block can also accept ignition signal input (IGN).

Warning

Please make sure the voltage of DC power is correct before you connect it to the system. Supplying a voltage over 48V will damage the system.

24 3-pin Remote On/ Off

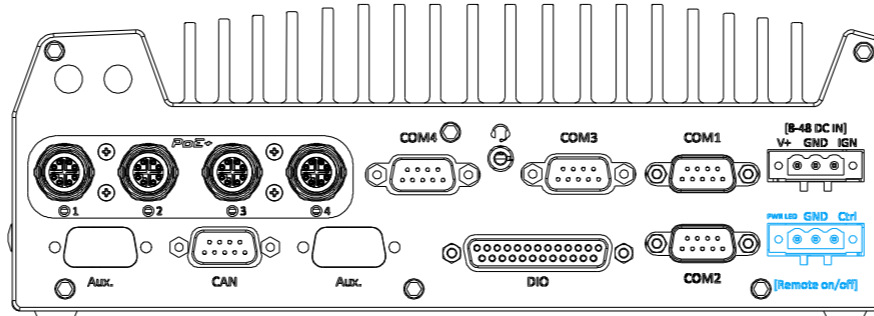

The "Remote On/ Off" 3-pin connection allows for the connection of an external non-latched switch to turn on/ off the system. It is useful when the system is placed in a cabinet or a not easily accessed location. You may connect an external status LED (20mA) indicator by connecting to PWR LED and GND.

25 Nuvo-9100VTC Damping Bracket Installation

The damping bracket comes standard with the system to provide shock and vibration resistance for in-vehicle conditions. Please refer to the exploded view for wall-mount installation.

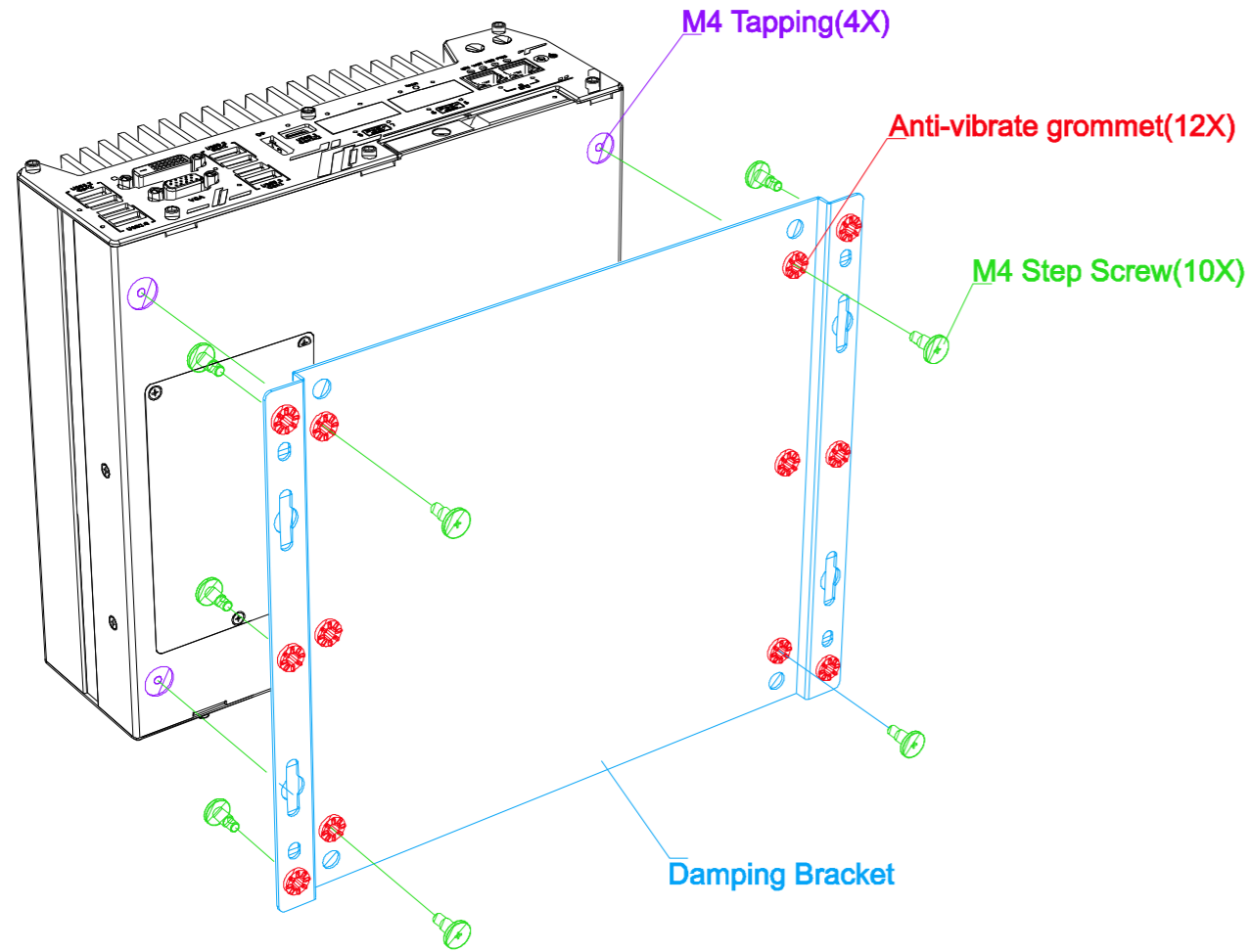

Note

If you are wall mounting the system, place the heatsink fins perpendicular to the ground for better heat dissipation efficiency.

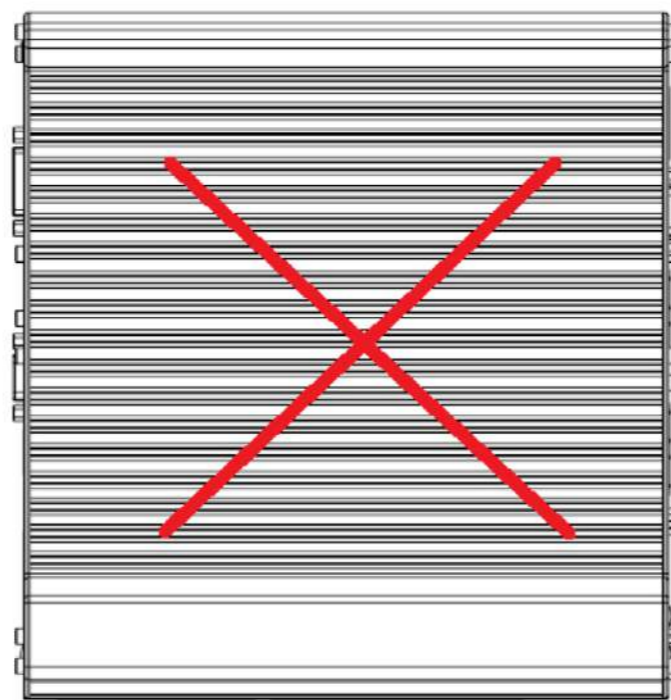
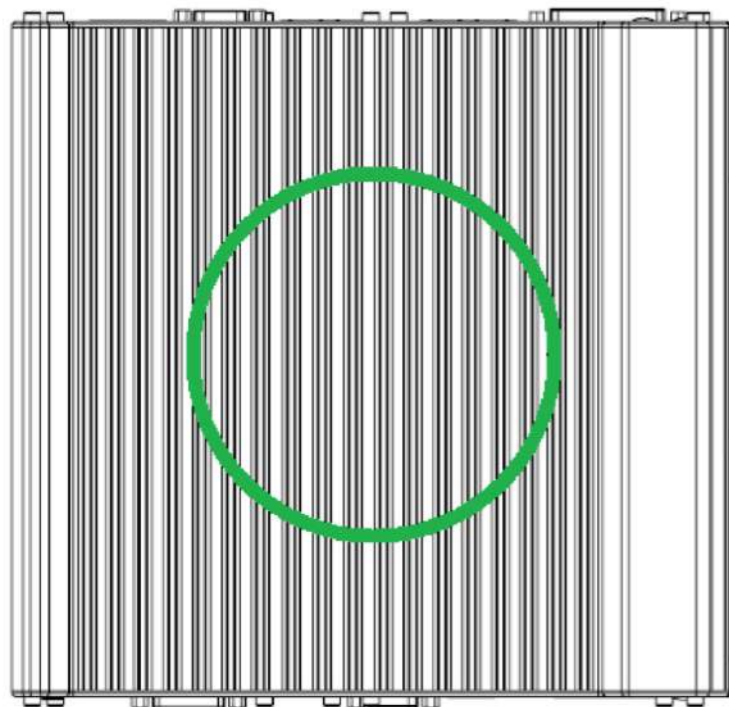

26 Nuvo-9200VTC Damping Bracket Installation

a. Available in the accessory box, take out the two brackets and secure them using the six M4 screws provided.

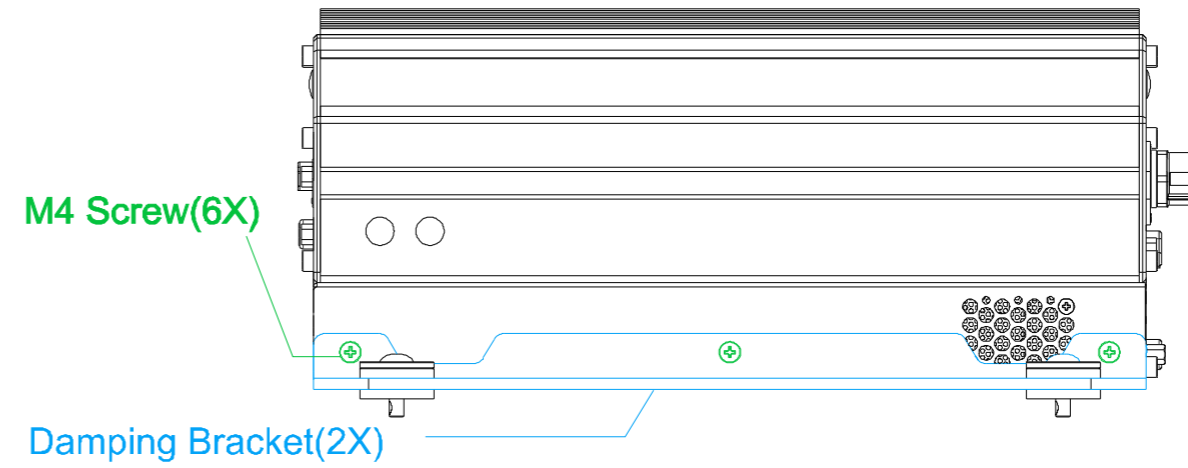

b. Please refer to the exploded view for wall-mount installation.

